

# F3000RU Series

## Ultra-Wide 4:1 Input, 30W Single & Dual Output DC/DC Converters



### Key Features:

- 30W Output Power
- 4:1 Input Voltage Range
- 1,600 VDC Isolation
- High Efficiency
- Compact 2 x 1.6 In. Case
- Industry Standard Pin-Out
- Remote ON/OFF
- Low Output Voltages



### Electrical Specifications

Specifications typical @ +25°C, nominal input voltage & rated output current, unless otherwise noted. Specifications subject to change without notice.

Input						
Parameter	Conditions	Min.	Typ.	Max.	Units	
Input Voltage Range	24 VDC Input	10.0	24.0	40.0	VDC	
	48 VDC Input	36.0	48.0	75.0		
Input Filter	π (Pi) Filter					
Output						
Parameter	Conditions	Min.	Typ.	Max.	Units	
Output Voltage Accuracy			±2.0		%	
Line Regulation	For Vin Min to Max		±0.5		%	
Load Regulation	I <sub>out</sub> = 10% to 100%		±1.0		%	
Ripple, See Note 1	2.5, 3.3, 5.0 VDC Output			100	mV P - P	
	All Other Outputs			±1.0	%	
Noise, See Note 1	1.8, 2.5, 3.3 VDC Output			100	mV P - P	
	All Other Outputs			±1.0	%	
Output Power Protection, See Note 2		120			%	
Over Voltage Protection, See Note 3		112		130	%	
Temperature Coefficient			±0.01	±0.02	%/°C	
Output Short Circuit	Continuous (Autorecovery)					
General						
Parameter	Conditions	Min.	Typ.	Max.	Units	
Isolation Voltage	60 Seconds	1,600			VDC	
Isolation Resistance	500 VDC	1,000			MΩ	
Isolation Capacitance	100 kHz, 1V		1,000		pF	
Switching Frequency			400		kHz	
Remote On/Off (Note 4)						
Parameter	Conditions	Min.	Typ.	Max.	Units	
Supply On		5.0		15.0	VDC	
Supply Off		0.0		0.5	VDC	
Input Current (On)				-1	mA	
Input Current (Off)				1	mA	
Control Common	Referenced to Negative Input (pin 2)					
Environmental						
Parameter	Conditions	Min.	Typ.	Max.	Units	
Operating Temperature Range	Ambient	-25		+70	°C	
Operating Temperature Range	Case			+100	°C	
Storage Temperature Range		-55		+105	°C	
Cooling	See Derating Curve					
Humidity	RH, Non-condensing			95	%	
Physical						
Case Size	2.0 x 1.6 x 0.47 Inches (50.8 x 40.6 x 11.9 mm)					
Case Material	Nickel Coated Copper with Non-Conductive Base					
Weight	2.11 Oz (58g)					
Reliability Specifications						
Parameter	Conditions	Min.	Typ.	Max.	Units	
MTBF	MIL HDBK 217F, 25°C, Gnd Benign	550			kHours	
Absolute Maximum Ratings						
Parameter	Conditions	Min.	Typ.	Max.	Units	
Input Voltage Surge (0.1 Sec)	24 VDC Input	-0.7		50.0	VDC	
	48 VDC Input	-0.7		100.0		
Lead Temperature	1.5 mm From Case For 10 Sec			260	°C	

Caution: Exceeding Absolute Maximum Ratings may damage the module. These are not continuous operating ratings.

### MicroPower Direct

292 Page Street  
Suite D  
Stoughton, MA 02072  
USA

T: (781) 344-8226  
F: (781) 344-8481  
E: sales@micropowerdirect.com  
W: www.micropowerdirect.com



[www.micropowerdirect.com](http://www.micropowerdirect.com)

Model Number	Input				Output			Maximum Output Power (W)	Efficiency (% Typ)	Capacitive Load (μF Max)	Fuse Rating Slow-Blow (mA)
	Voltage (VDC)		Current (mA)		Voltage (VDC)	Current (mA, Max)	Current (mA, Min)				
	Nominal	Range	Full-Load	No-Load							
F3001RU	24	10.0 - 40.0	781	85	2.5	6,000	600.0	15.0	80	33,000	2,000
F3002RU	24	10.0 - 40.0	993	85	3.3	6,000	600.0	19.8	83	19,500	2,000
F3003RU	24	10.0 - 40.0	1,470	85	5.0	6,000	600.0	30.0	85	10,200	3,000
F3004RU	24	10.0 - 40.0	1,506	85	12.0	2,500	250.0	30.0	83	820	3,000
F3005RU	24	10.0 - 40.0	1,506	85	15.0	2,000	200.0	30.0	83	420	3,000
F3006RU	24	10.0 - 40.0	1,488	85	24.0	1,250	125.0	30.0	84	180	3,000
F3007RU	24	10.0 - 40.0	1,543	85	±5.0	±3,000	±300.0	30.0	81	±4,800	3,000
F3008RU	24	10.0 - 40.0	1,506	85	±12.0	±1,250	±125.0	30.0	83	±560	3,000
F3009RU	24	10.0 - 40.0	1,506	85	±15.0	±1,000	±100.0	30.0	83	±470	3,000
F3011RU	48	18.0 - 75.0	386	50	2.5	6,000	600.0	15.0	81	33,000	1,000
F3012RU	48	18.0 - 75.0	485	50	3.3	6,000	600.0	19.8	85	19,500	1,000
F3013RU	48	18.0 - 75.0	718	50	5.0	6,000	600.0	30.0	87	10,200	2,000
F3014RU	48	18.0 - 75.0	744	50	12.0	2,500	250.0	30.0	84	820	2,000
F3015RU	48	18.0 - 75.0	744	50	15.0	2,000	200.0	30.0	84	420	2,000
F3016RU	48	18.0 - 75.0	744	50	24.0	1,250	125.0	30.0	84	180	2,000
F3017RU	48	18.0 - 75.0	762	50	±5.0	±3,000	±300.0	30.0	82	±4,800	2,000
F3018RU	48	18.0 - 75.0	744	50	±12.0	±1,250	±125.0	30.0	84	±560	2,000
F3019RU	48	18.0 - 75.0	753	50	±15.0	±1,000	±100.0	30.0	83	±470	2,000

Notes:

- When measuring output ripple, it is recommended that an external 1.0 μF ceramic in parallel with a 10 μF capacitor be placed from the +Vout pin to the -Vout pin.
- The unit will recover automatically when the fault condition is removed.
- Over voltage protection is provided by a zener diode clamp.
- If the on/off pin (Pin 4) is left open, the unit operates.
- No load operation will not damage these units, but they may not meet all spec's.
- It is recommended that a fuse be used on the input of a power supply for protection. See the table above for the correct rating.

Pin Connections

Pin	Single	Dual	Pin	Single	Dual
1	+Vin	+Vin	6	+Vout	Common
2	-Vin	-Vin	7	-Vout	-Vout
4	ON/OFF	ON/OFF	8	Trim	Trim
5	No Pin	+Vout			

External Trim

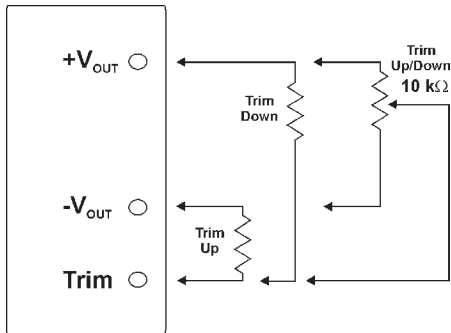

A simple external circuit may be used to adjust the converter output. The adjustment range is ±10%.  
 To adjust the output DOWN, connect a 5%, 3W resistor between the plus output pin and the Vout trim pin. To adjust the output UP, connect a 5%, 3W resistor between the minus output pin and the Vout trim pin.  
 For UP/Down trimming capability, connect a 10 kW potentiometer between the plus and minus outputs with the wiper arm connected to the Vout trim pin.

Derating Curves

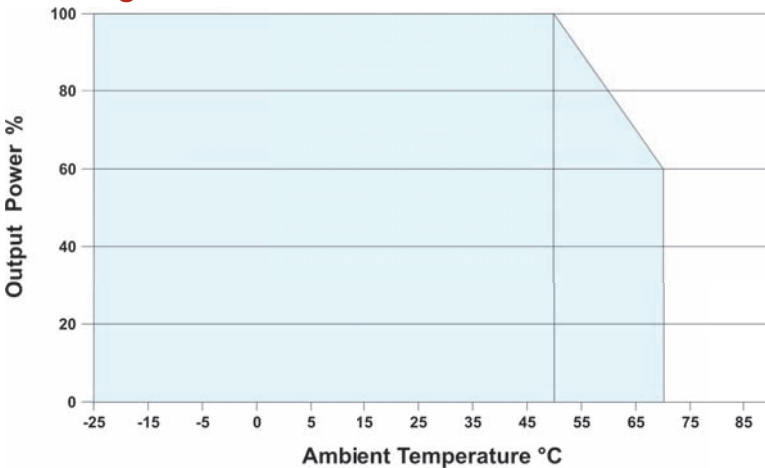

Mechanical Dimensions

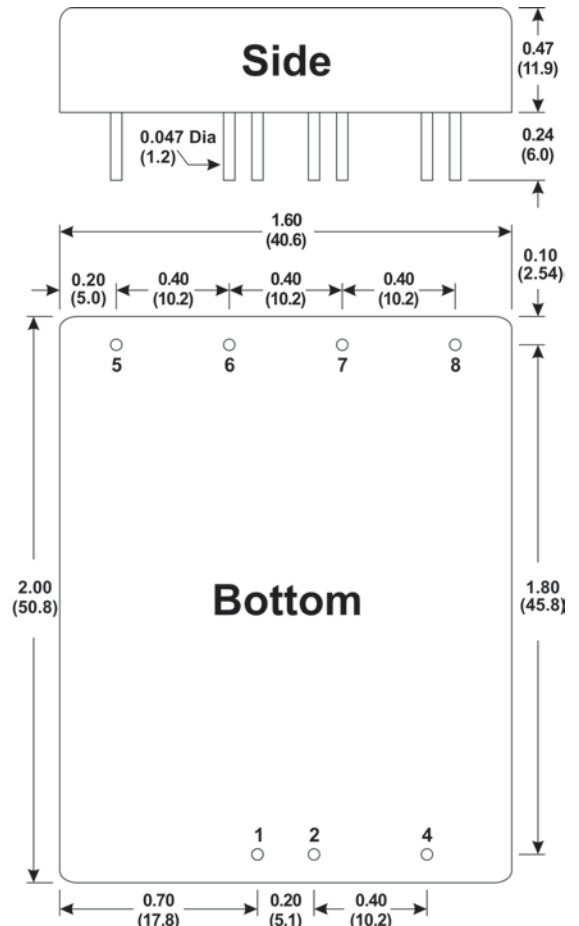

Mechanical Notes:

- All dimensions are typical in inches (mm)
- Tolerance x.xx = ±0.01 (±0.25)



**MicroPower Direct**  
 We Power Your Success - For Less!