

C4000RW Series



Wide 2:1 Input 40W Single, Dual & Triple Output DC/DC Converters

Electrical Specifications

Specifications typical @ +25°C, nominal input voltage & rated output current, unless otherwise noted. Specifications subject to change without notice.

Key Features:

- 40W Output Power
- 2:1 Input Voltage Range
- 1,600 VDC Isolation
- 12, 24, & 48V Input
- Single, Dual, Triple Output
- Remote ON/OFF
- >550 kHour MTBF
- Industry Standard Pin-Out



Input

Parameter	Conditions	Min.	Typ.	Max.	Units
Input Voltage Range	12 VDC Input	9.0	12.0	18.0	VDC
	24 VDC Input	18.0	24.0	36.0	
	48 VDC Input	36.0	48.0	75.0	
Input Filter	π (Pi) Filter				

Output

Parameter	Conditions	Min.	Typ.	Max.	Units
Output Voltage Accuracy, See Note 1			±2.0		%
Line Regulation, Single, Dual Output	For Vin Min to Max		±0.5		%
	Vout 1		±1.0		%
Line Regulation, Triple Output	Vout 2 & Vout 3		±5.0		%
Load Regulation, Single Output	Iout = 10% to 100%		±1.0		%
Load Regulation, Dual Output	Iout = 10% to 100%		±2.0		%
Load Regulation, Triple Output	Iout = 10% to 100%, Vout 1		±3.0		%
	Iout = 10% to 100%, Vout 2 & Vout 3		±5.0		%
Ripple, See Note 2	Single Output Models			±1.0	%
	Dual/Triple Output Models		0.2% Vout + 20 mV P - P Max.		
Noise, See Note 2	5V Output Models			100	mV
	12V, 15V & 24V Output Models			±1.0	%
	Dual/Triple Output Models		0.5% Vout + 50 mV P - P Max.		
Output Power Protection, See Note 3		120			%
Over Voltage Protection, See Note 4		112		165	%
Temperature Coefficient			±0.02		%/°C
Output Short Circuit	Continuous (Autorecovery)				

General

Parameter	Conditions	Min.	Typ.	Max.	Units
Isolation Voltage	60 Seconds	1,600			VDC
Isolation Resistance	500 VDC	1,000			MΩ
Isolation Capacitance	100 kHz, 1V		1,000		pF
	5V Output Models		250		
Switching Frequency, See Note 5	12V Output Models		200		kHz
	All Other Models		400		

Remote On/Off, See Note 6

Parameter	Conditions	Min.	Typ.	Max.	Units
Supply On		5.0		15.0	VDC
Supply Off		-1.0		+1.0	VDC
Input Current (On)				-1	mA
Input Current (Off)				1	mA
Control Common	Referenced to Negative Input (pin 2)				

Environmental

Parameter	Conditions	Min.	Typ.	Max.	Units
Operating Temperature Range	Ambient	-25		+70	°C
Operating Temperature Range	Case			+100	°C
Storage Temperature Range		-55		+105	°C
Cooling	See Derating Curve				
Humidity	RH, Non-condensing			95	%

Physical

Case Size	2.0 x 2.0 x 0.45 Inches (50.8 x 50.8 x 11.4 mm)				
Case Material	Nickel Coated Copper with Non-Conductive Base				
Weight	2.47 Oz (70g)				

Reliability Specifications

Parameter	Conditions	Min.	Typ.	Max.	Units
MTBF	MIL HDBK 217F, 25°C, Gnd Benign	550			kHours

Absolute Maximum Ratings

Parameter	Conditions	Min.	Typ.	Max.	Units
Input Voltage Surge (0.1 Sec)	12 VDC Input	-0.7		25.0	VDC
	24 VDC Input	-0.7		50.0	
	48 VDC Input	-0.7		100.0	
Lead Temperature	1.5 mm From Case For 10 Sec			260	°C

Caution: Exceeding Absolute Maximum Ratings may damage the module. These are not continuous operating ratings.

MicroPower Direct

292 Page Street
Suite D
Stoughton, MA 02072
USA

T: (781) 344-8226
F: (781) 344-8481
E: sales@micropowerdirect.com
W: www.micropowerdirect.com



www.micropowerdirect.com

Model Number	Input				Output 1		Output 2		Output 3		Max. Output Power (W)	Efficiency (Typ %)	Capacitive Load (µF Max)	Fuse Rating Slow-Blow (mA)
	Voltage (VDC)		Current (mA)		Voltage (VDC)	Current (A, Max)	Voltage (VDC)	Current (A, Max)	Voltage (VDC)	Current (A, Max)				
	Nom.	Range	Full-Load	No-Load										
C4001RW	12	9 - 18	3,922	120	5.0	8.00					40.0	85	13,600	8,500
C4002RW	12	9 - 18	3,922	120	12.0	3.33					40.0	85	1,800	8,500
C4003RW	12	9 - 18	3,922	120	15.0	2.66					40.0	85	1,200	8,500
C4004RW	12	9 - 18	3,922	120	24.0	1.66					40.0	85	330	8,500
C4005RW	12	9 - 18	3,557	120	+5.0	+3.50	-5.0	-3.50			35.0	82	±1,000	8,500
C4006RW	12	9 - 18	3,922	120	+12.0	+1.66	-12.00	-1.66			40.0	85	±150	8,500
C4007RW	12	9 - 18	3,922	120	+15.0	+1.32	-15.00	-1.32			40.0	85	±82	8,500
C4008RW	12	9 - 18	3,922	120	5.0	5.00	+12.0	+0.60	-12.0	-0.60	40.0	85	1,000/ ±120	8,500
C4009RW	12	9 - 18	3,922	120	5.0	5.00	+15.0	+0.50	-15.0	-0.50	40.0	85	1,000/ ±82	8,500
C4011RW	24	18 - 36	1,915	85	5.0	8.00					40.0	87	13,600	4,500
C4012RW	24	18 - 36	1,938	85	12.0	3.33					40.0	86	1,800	4,500
C4013RW	24	18 - 36	1,938	85	15.0	2.66					40.0	86	1,200	4,500
C4014RW	24	18 - 36	1,938	85	24.0	1.66					40.0	86	330	4,500
C4015RW	24	18 - 36	1,757	85	+5.0	+3.50	-5.0	-3.50			35.0	83	±1,000	4,500
C4016RW	24	18 - 36	1,938	85	+12.0	+1.66	-12.00	-1.66			40.0	86	±150	4,500
C4017RW	24	18 - 36	1,938	85	+15.0	+1.32	-15.00	-1.32			40.0	86	±82	4,500
C4018RW	24	18 - 36	1,938	85	5.0	5.00	+12.0	+0.60	-12.0	-0.60	40.0	86	1,000/ ±120	4,500
C4019RW	24	18 - 36	1,938	85	5.0	5.00	+15.0	+0.50	-15.0	-0.50	40.0	86	1,000/ ±82	4,500
C4021RW	48	36 - 75	947	50	5.0	8.00					40.0	88	13,600	2,500
C4022RW	48	36 - 75	957	50	12.0	3.33					40.0	87	1,800	2,500
C4023RW	48	36 - 75	957	50	15.0	2.66					40.0	87	1,200	2,500
C4024RW	48	36 - 75	957	50	24.0	1.66					40.0	87	330	2,500
C4025RW	48	36 - 75	868	50	+5.0	+3.50	-5.0	-3.50			35.0	84	±1,000	2,500
C4026RW	48	36 - 75	957	50	+12.0	+1.66	-12.00	-1.66			40.0	87	±150	2,500
C4027RW	48	36 - 75	957	50	+15.0	+1.32	-15.00	-1.32			40.0	87	±82	2,500
C4028RW	48	36 - 75	957	50	5.0	5.00	+12.0	+0.60	-12.0	-0.60	40.0	87	1,000/ ±120	2,500
C4029RW	48	36 - 75	957	50	5.0	5.00	+15.0	+0.50	-15.0	-0.50	40.0	87	1,000/ ±82	2,500

Notes:

- For triple output models, the voltage accuracy of the auxiliary outputs is ±5%.
- When measuring output ripple, it is recommended that an external 1.0 µF ceramic in parallel with a 10 µF capacitor be placed from the +Vout pin to the -Vout pin.
- The unit will recover automatically when the fault condition is removed.
- Over voltage protection is provided by a zener diode clamp.
- Typical switching frequency for 12V input models is 200 kHz.
- If the on/off pin (Pin 4) is left open, the unit operates.
- No load operation will not damage these units, but they may not meet all spec's.
- It is recommended that a fuse be used on the input of a power supply for protection. See the table above for the correct rating.

Derating Curve

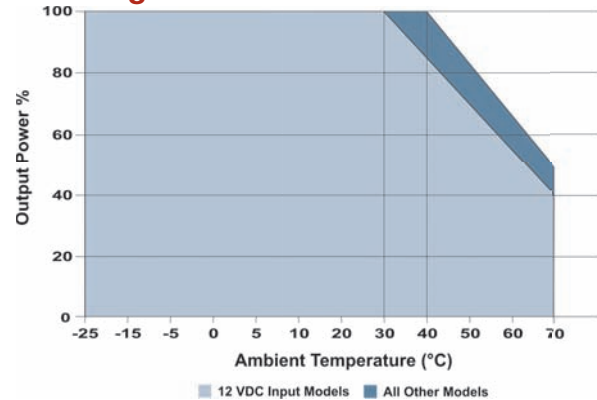

Mechanical Dimensions

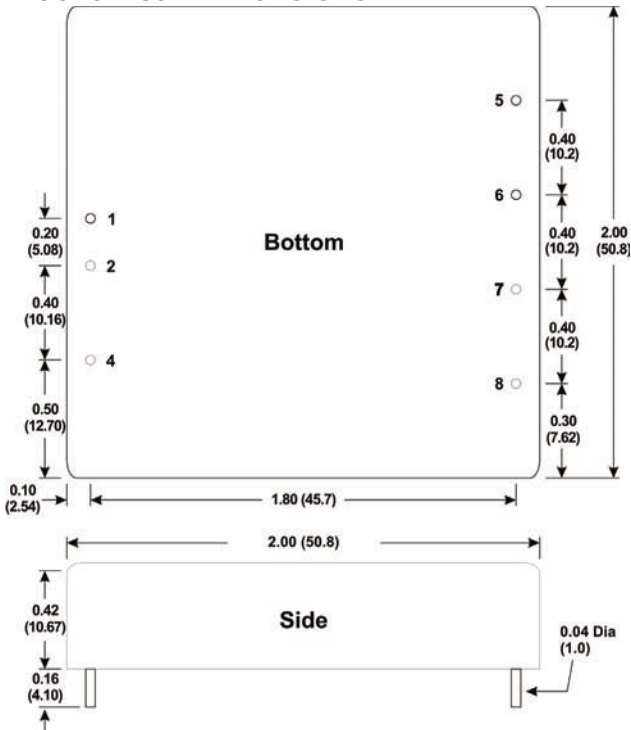

Pin Connections

Pin	Single	Dual	Triple
1	+Vin	+Vin	+Vin
2	-Vin	-Vin	-Vin
4	On/Off	On/Off	On/Off
5	NC	Vout 1	Vout 2
6	+Vout	Common	Vout 1
7	-Vout	Vout 2	Common
8	Trim	Trim	Vout 3

NC = No Connection

Mechanical Notes:

- All dimensions are typical in inches (mm)
- Tolerance x.xx = ±0.01 (±0.25)

External Trim

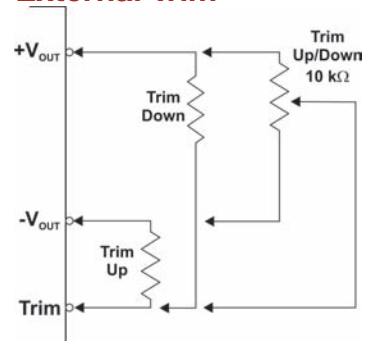

A simple external circuit may be used to adjust the converter output. To adjust the output DOWN, connect a 5%, 3W resistor between the plus output pin and the Vout trim pin. To adjust the output UP, connect a 5%, 3W resistor between the minus output pin and the Vout trim pin. For UP/Down trimming capability, connect a 10 kW potentiometer between the plus and minus outputs with the wiper arm connected to the Vout trim pin. The range for the external trim is about ±10%.



MicroPower Direct
We Power Your Success - For Less!