

A300RU Series

Single & Dual Output, 3W Ultra-Wide Input Range DC/DC Converters



Key Features:

- 3W Output Power
- 4:1 Input Voltage Range
- 1,500 VDC Isolation
- EN 60950 Compliant
- Meets EN55022 “A”
- Single & Dual Outputs
- 1.0 MH MTBF
- Industry Standard Pin-Out



MicroPower Direct

292 Page Street
Suite D
Stoughton, MA 02072
USA

T: (781) 344-8226
F: (781) 344-8481
E: sales@micropowerdirect.com
W: www.micropowerdirect.com



Electrical Specifications

Specifications typical @ +25°C, nominal input voltage & rated output current, unless otherwise noted. Specifications subject to change without notice.

Input

Parameter	Conditions	Min.	Typ.	Max.	Units
Input Start Voltage	24 VDC Input	6.0	7.5	9.0	VDC
	48 VDC Input	12.0	15.0	18.0	
Under Voltage Shutdown	24 VDC Input			8.5	VDC
	48 VDC Input			16.0	
Input Filter	π (Pi) Filter (Meets EN55022 Class “A”)				
Reverse Polarity Input Current				0.5	A
Short Circuit Input Power			2,000		mW

Output

Parameter	Conditions	Min.	Typ.	Max.	Units
Output Voltage Accuracy			±0.5	±2.0	%
Output Voltage Balance	Dual Output , Balanced Loads		±0.5	±3.0	%
Line Regulation	V_{in} = Min to Max		±0.2	±1.0	%
Load Regulation	I_{out} = 10% to 100%		±0.3	±1.0	%
Ripple & Noise (20 MHz)	See Note 1		40	75	mV P - P
Ripple & Noise (20 MHz)	Over Line, Load & Temp			150	mV P - P
Ripple & Noise (20 MHz)				15	mV rms
Output Power Protection	V_{in} = Min	110			%
Transient Recovery Time, See Note 2	25% Load Step Change		150	500	µSec
Transient Response Deviation			±2.0		%
Temperature Coefficient			±0.01	±0.02	%/°C
Output Short Circuit	Continuous (Autorecovery)				

General

Parameter	Conditions	Min.	Typ.	Max.	Units
Isolation Voltage	60 Seconds	1,500			VDC
Isolation Resistance	500 VDC	1,000			MΩ
Isolation Capacitance	100 kHz/1V		380	500	pF
Switching Frequency			350		kHz

Environmental

Parameter	Conditions	Min.	Typ.	Max.	Units
Operating Temperature Range	Ambient	-40		+71	°C
Operating Temperature Range	Case			+90	°C
Storage Temperature Range		-55		+125	°C
Cooling	Free Air Convection				
Humidity	RH, Non-condensing		95		%

Physical

Case Size	1.25 x 0.80 x 0.40 Inches (31.8 x 20.3 x 10.2 mm)				
Case Material	Non-Conductive Black Plastic (UL94V-0)				
Weight	0.42 Oz (12.2g)				

Reliability Specifications

Parameter	Conditions	Min.	Typ.	Max.	Units
MTBF	MIL HDBK 217F, 25°C, Gnd Benign	1.0			MHours

Absolute Maximum Ratings

Parameter	Conditions	Min.	Typ.	Max.	Units
Input Voltage Surge (1 Sec)	24 VDC Input	-0.7		50.0	VDC
	48 VDC Input	-0.7		100.0	
Lead Temperature	1.5 mm From Case For 10 Sec			260	°C
Internal Power Dissipation	All Models			2,500	mW

Caution: Exceeding Absolute Maximum Ratings may damage the module. These are not continuous operating ratings.

www.micropowerdirect.com

Model Number	Input				Reflected Ripple Current (mA, Typ)	Output			Efficiency (% , Typ)	Fuse Rating Slow-Blow (mA)
	Voltage (VDC)		Current (mA)			Voltage (VDC)	Current (mA, Max)	Current (mA, Min)		
	Nominal	Range	Full-Load	No-Load						
A301RU	24	9.0 - 36.0	138	20	10	3.3	750	93.0	75	1,000
A302RU	24	9.0 - 36.0	158	20	10	5.0	600	75.0	79	1,000
A303RU	24	9.0 - 36.0	154	20	10	12.0	250	32.0	81	1,000
A304RU	24	9.0 - 36.0	152	20	10	15.0	200	25.0	82	1,000
A305RU	24	9.0 - 36.0	156	20	10	±12.0	±125	±16.0	80	1,000
A306RU	24	9.0 - 36.0	156	20	10	±15.0	±100	±13.0	80	1,000
A311RU	48	18.0 - 75.0	68	10	10	3.3	750	93.0	76	500
A312RU	48	18.0 - 75.0	78	10	10	5.0	600	75.0	80	500
A313RU	48	18.0 - 75.0	75	10	10	12.0	250	32.0	83	500
A314RU	48	18.0 - 75.0	74	10	10	15.0	200	25.0	84	500
A315RU	48	18.0 - 75.0	76	10	10	±12.0	±125	±16.0	82	500
A316RU	48	18.0 - 75.0	76	10	10	±15.0	±100	±13.0	82	500

Notes:

- When measuring output ripple, it is recommended that an external 0.47 µF ceramic capacitor be placed from the +Vout pin to the -Vout pin for single output units and from each output to common for dual output units. For noise sensitive applications, the use of 3.3 µF capacitors will reduce the output ripple.
- Transient recovery is measured to within a 1% error band for a load step change of 75% to 100%.
- Operation at no-load will not damage these units. However, they may not meet all specifications.
- Dual output units may be connected to provide a 24 VDC or 30 VDC output. To do this, connect the load across the positive (+Vout) and negative (-Vout) outputs and float the output common.
- The converter should be connected to a low ac-impedance source. An input source with a highly inductive impedance may affect the stability of the converter. In applications where the converter output loading is high and input power is supplied over long lines, it may be necessary to use a capacitor on the input to insure start-up. In this case, it is recommended that a low ESR (ESR <1.0Ω at 100 kHz) capacitor be mounted close to the converter. For 24V input units a 4.7 µF is recommended; and for 48V units a 2.2 µF.
- It is recommended that a fuse be used on the input of a power supply for protection. See the table above for the correct rating.

Derating Curve

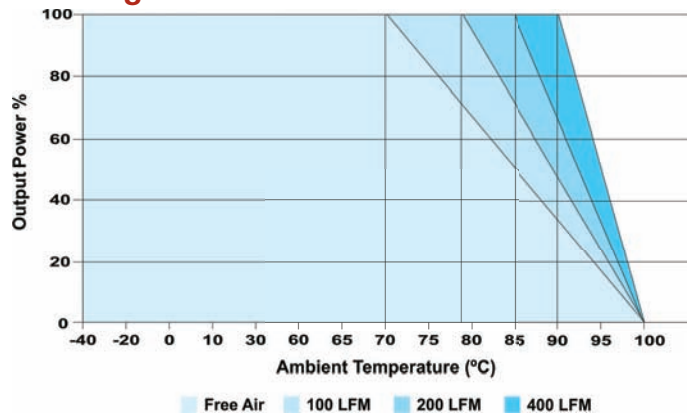

Capacitive Load

Vout	Maximum Load Capacitance	Vout	Maximum Load Capacitance
3.3 VDC	680 µF	±12 VDC	150 µF
5 VDC	470 µF	±15 VDC	100 µF
12 VDC	330 µF		
15 VDC	220 µF		

Pin Connections

Pin	Single	Dual
2, 3	-Vin	-Vin
9	No Pin	Common
11	NC	-Vout
14	+Vout	+Vout
16	-Vout	Common
22, 23	+Vin	+Vin

NC: No Connection

Mechanical Dimensions

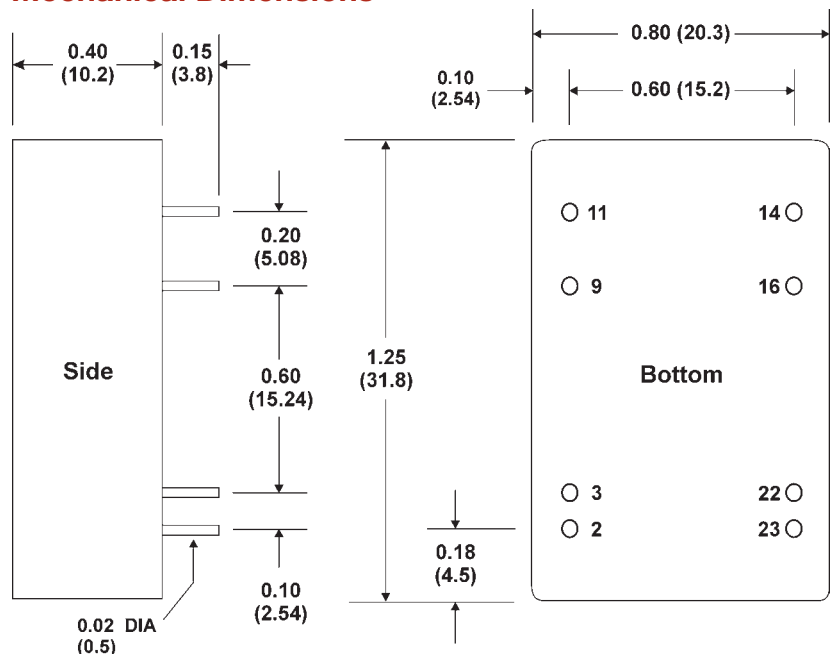

Mechanical Notes:

- All dimensions are typical in inches (mm)
- Tolerance x.xx = ±0.01 (±0.25)



MicroPower Direct
We Power Your Success - For Less!