

# MPM-03 Series

## Single Output, 3W Ultra-Miniature DIP AC/DC Power Supplies



### Key Features:

- 3W Output Power
- Universal 85-264 VAC Input
- EN 60950 Approved (UL)
- Meets IEC Safety Class II
- -25°C to +70°C Operation
- Single Regulated Output
- >200 kHour MTBF
- Ultra-Miniature DIP Case



### MicroPower Direct

292 Page Street  
Suite D  
Stoughton, MA 02072  
USA

T: (781) 344-8226

F: (781) 344-8481

E: sales@micropowerdirect.com

W: www.micropowerdirect.com



### Electrical Specifications

Specifications typical @ +25°C, 230 VAC input voltage & rated output current, unless otherwise noted. Specifications subject to change without notice.

#### Input

Parameter	Conditions	Min.	Typ.	Max.	Units
Input Voltage Range		85		264	VAC
		120		370	VDC
Input Frequency		47		63	Hz
Input Current	See Model Selection Guide				
Inrush Current	115 VAC		10.0		A Pk
	230 VAC		20.0		

#### Output

Parameter	Conditions	Min.	Typ.	Max.	Units
Output Voltage	See Model Selection Guide				
Output Current	See Model Selection Guide				
Output Voltage Accuracy	See Note 1		±2.0		%
Line Regulation			±0.5		%
Load Regulation, See Note 2	See Model Selection Guide				
Ripple & Noise (20 MHz)		30			mV Pk - Pk
Hold-Up Time	115 VAC		30		mSec
	230 VAC		50		
Temperature Coefficient			±0.02		%/°C
Short Circuit Protection	Continuous (Autorecovery)				
Over Temperature Protection				150	°C

#### General

Parameter	Conditions	Min.	Typ.	Max.	Units
Isolation Voltage	Input to Output	3,000			VAC
EMC Compliance	EMI/RFI	Conducted EN 55022 Level A			
	EMC Compliance	Electrostatic Discharge (ESD)	EN 61000-4-2 Level 4 8 kV/15 kV		
		RF Field Susceptibility	EN 61000-4-3		
		Electrical Fast Transients/Bursts On Mains	EN 61000-4-4 Level 3 2 kV		
Switching Frequency	Surge	EN 61000-4-5 Level 3 1 kV/2 kV			
			100		kHz

#### Environmental

Parameter	Conditions	Min.	Typ.	Max.	Units
Operating Temperature Range	Ambient	-25	+25	+70	°C
Storage Temperature Range		-40		+105	°C
Cooling	Free Air Convection (See Derating Curve)				
Humidity	RH, Non-condensing			85	%

#### Physical

Case Size	1.46 x 0.90 x 0.59 Inches (37.0 x 23.0 x 15.0 mm)				
Case Material	Non-Conductive Black Plastic (UL94-V0)				
Weight	1.24 Oz (35g)				

#### Reliability Specifications

Parameter	Conditions	Min.	Typ.	Max.	Units
MTBF	MIL HDBK 217F, 25°C, Gnd Benign	200			kHours
Safety Standards	UL 60950, EN 60950				
Safety Approvals	UL, cUL; File No. E245422				
Safety Class	IEC 61140 Class II				

[www.micropowerdirect.com](http://www.micropowerdirect.com)

Model Number	Input		Voltage (VDC)	Output			Capacitive Load ( $\mu\text{F}$ , Max)	Efficiency (% Typ)
	Current (mA)			Current (mA)				
	115 VAC	230 VAC		Nom.	Peak (60S)	Load Reg.		
MPM-03S-03	65	30	3.3	700	900	$\pm 1.0\%$	680	63
MPM-03S-05	65	30	5.0	600	750	$\pm 1.0\%$	470	72
MPM-03S-09	65	30	9.0	330	450	$\pm 1.0\%$	330	74
MPM-03S-12	65	30	12.0	250	330	$\pm 1.0\%$	330	76
MPM-03S-15	65	30	15.0	200	250	$\pm 1.0\%$	200	76
MPM-03S-24	65	30	24.0	120	160	$\pm 1.0\%$	150	78

Notes:

1. Typical output voltage accuracy for 3.3V output models is  $\pm 3\%$ .
2. Load regulation is measured for an output change of 10% to 90% at nominal input line. For multiple output models, the loads are balanced.
3. Peak current ratings are given for 60S only. Operation at excessive output current levels may cause damage to the unit.
4. It is recommended that a fuse be used on the input of a power supply for protection. For the **MPM-03** series, a 0.5A/250V AC slow blow should be used.

Typical Connection

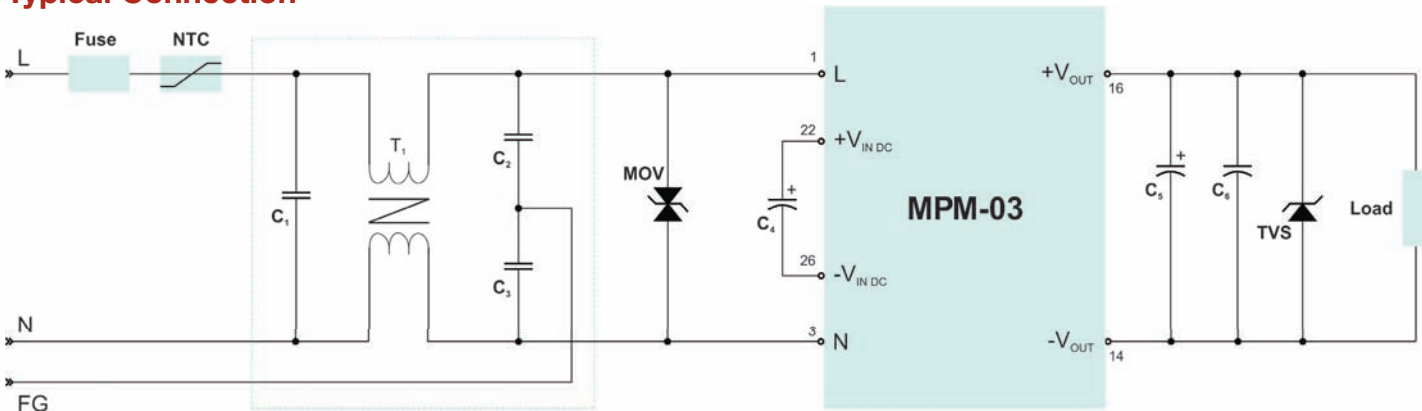

The diagram above illustrates a typical application connection of the **MPM-03** series. Notes on this circuit (starting with the input circuit) are:

1. To maintain clearance and creepage distances (for Class I & Class II devices) the board layout should guarantee the following spacing between the L and N inputs (before the fuse):

Clearance - 2 mm  
Creepage - 2.5 mm

2. The recommended fuse is a 0.5A/250V slow blow. Additionally, a thermistor (NTC) may be used on the input line. A 10 $\Omega$ /2W wire wound resistor or 5D-14 is recommended.
3. For EMI sensitive applications, the input filtering circuit (inside the dotted boxes) may be added. The filter consists of:
  - Cx: Capacitor C<sub>1</sub> is 0.1  $\mu\text{F}$ /275V
  - Cy: Capacitors C<sub>2</sub> and C<sub>3</sub> are 220 pF/2000V
  - T<sub>1</sub>: Common mode choke, UU9.8 or ring core. Inductance is about 10 mH to 30 mH & wire diameter of 0.22 mm.
4. The MOV is required for surge protection. Recommended is a 471KD07.

V <sub>OUT</sub>	C <sub>5</sub>	C <sub>6</sub>
3.3	47 $\mu\text{F}$	0.1 $\mu\text{F}$
5.0	47 $\mu\text{F}$	0.1 $\mu\text{F}$
9.0	33 $\mu\text{F}$	0.1 $\mu\text{F}$
12.0	33 $\mu\text{F}$	0.1 $\mu\text{F}$
15.0	33 $\mu\text{F}$	0.1 $\mu\text{F}$
24.0	10 $\mu\text{F}$	0.1 $\mu\text{F}$

5. The input filtering capacitor (C<sub>4</sub>) is an electrolytic 4.7  $\mu\text{F}$ /400V. This capacitor must be used for AC input applications.
6. The output filtering capacitor (C<sub>5</sub>) is a high frequency, low resistance electrolytic capacitor. A ceramic capacitor (C<sub>6</sub>) is used to filter high frequency noise. Recommended values are given in the table at right.
7. The TVS is recommended to protect application circuitry in the event of a fault.

Mechanical Dimensions

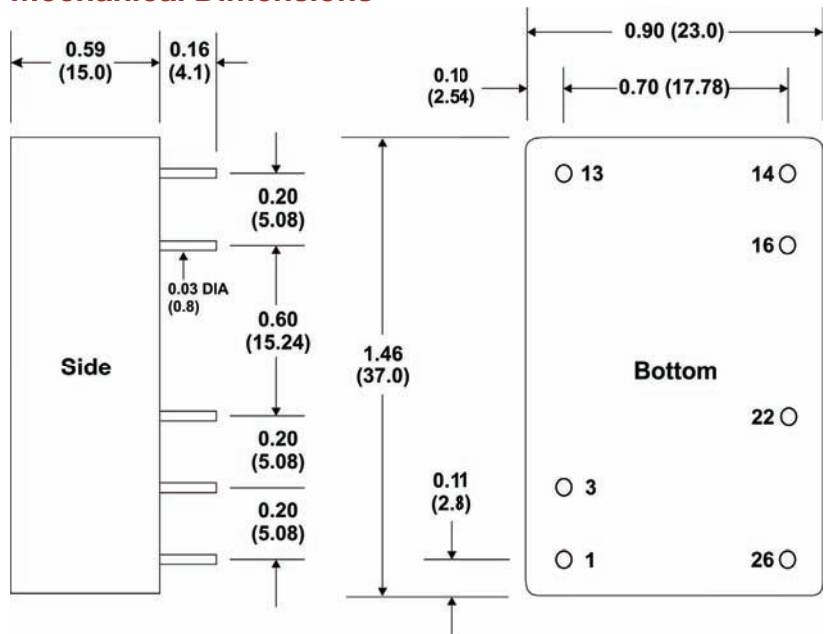

Notes:

- All dimensions are typical in inches (mm)
- Tolerance x.xx =  $\pm 0.01$  ( $\pm 0.25$ )

Derating Curve

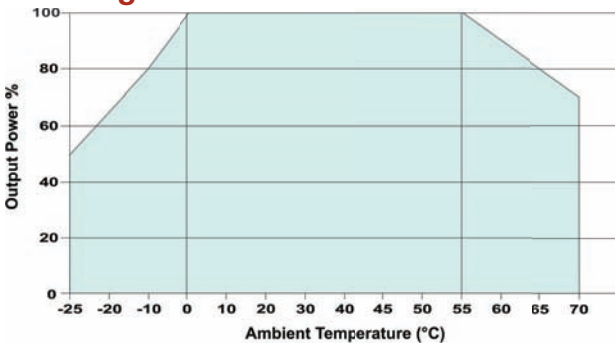

Pin Connections

Pin	Function
1	AC-Line
3	AC-Neutral
13	NC
14	-V <sub>out</sub>
16	+V <sub>out</sub>
22	+V <sub>in</sub> (DC)
26	-V <sub>in</sub> (DC)



**MicroPower Direct**  
We Power Your Success - For Less!